

# Feather<sub>CHAIR</sub>

## *Feather Power Chair Owner's Manual*

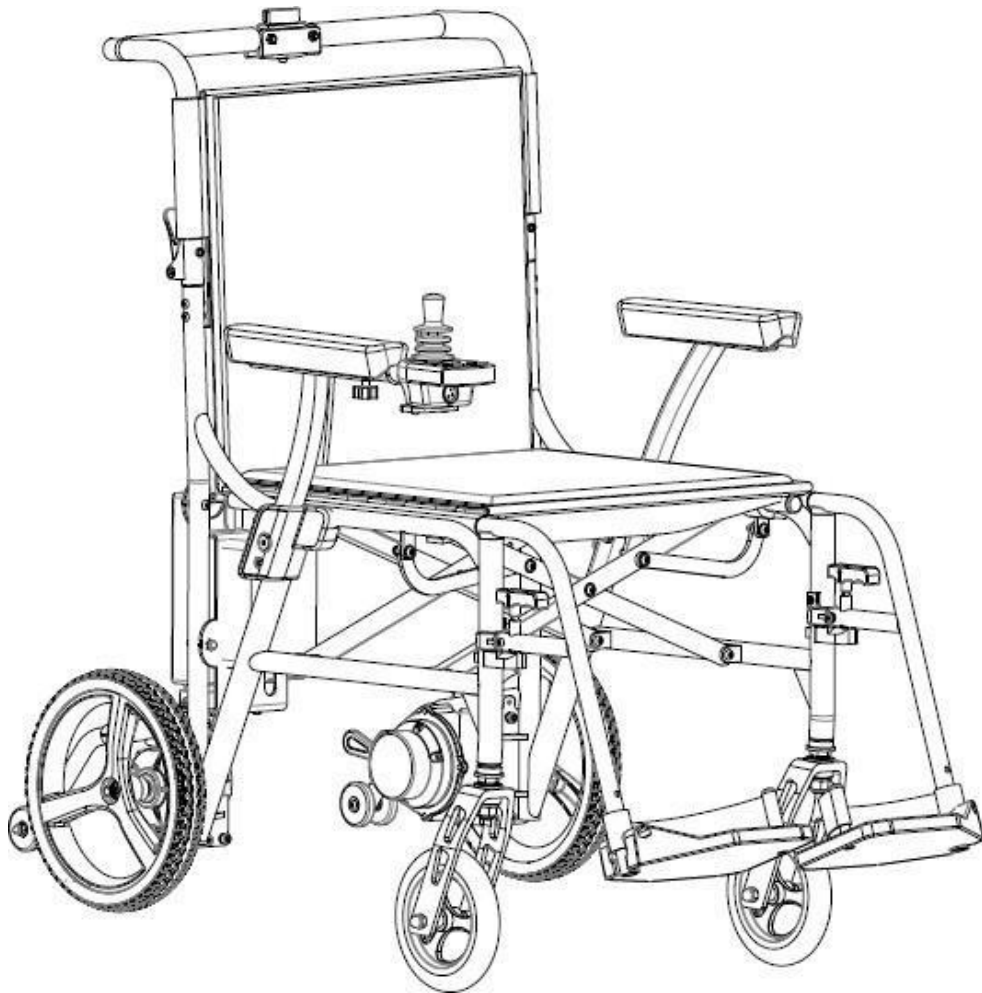



**ATTENTION:** Please read the content of your owner's manual before operating your Electrical Power Wheelchair

## Safety Guidelines

 **WARNING!** An authorized provider or a qualified technician must perform the initial setup of this power chair and must perform all of the procedures in this manual.

The symbols below are used throughout this owner's manual and on the power chair to identify warnings and important information. It is very important for you to read them and understand them completely.

 **WARNING!** Indicates a potentially hazardous condition/situation. Failure to follow designated procedures can cause either personal injury, component damage, or malfunction. On the product, this icon is represented as a black symbol on a yellow triangle with a black border.

 **MANDATORY!** These actions should be performed as specified. Failure to perform mandatory actions can cause personal injury and/or equipment damage. On the product, this icon is represented as a white symbol on a blue dot with a white border.

 **PROHIBITED!** These actions are prohibited. These actions should not be performed at any time or in any circumstances. Performing a prohibited action can cause personal injury and/or equipment damage. On the product, this icon is represented as a black symbol with a red circle and red slash.

### Intended Use

The intended use of the FeatherChair Mobility Products device is to provide mobility to persons limited to a seated position that have the capacity of operating a powered wheelchair.

### Regarding Devices for Prescription Use

### Quick Reference Information

**NOTE:** *This owner's manual is compiled from the latest specifications and product information available at the time of publication. We reserve the right to make changes as they become necessary. Any changes to our products may cause slight variations between the illustrations and explanations in this manual and the*

*product you have purchased. The latest/current version of this manual is available on our website.*

**NOTE:** *This product is compliant with WEEE, RoHS, and REACH directives and requirements.*

**NOTE:** *This product meets IPX4 classification (IEC 60529).*

**NOTE:** *This product and its components are not made with natural rubber latex. Consult with the manufacturer regarding any after-market accessories.*

Rev A / Aug 2020



## Table of Contents

<b>Introduction .....</b>	<b>4</b>
<b>Safety .....</b>	<b>5</b>
<b>Your Power Chair.....</b>	<b>7</b>
<b>Assembly/Disassembly .....</b>	<b>10</b>
<b>Comfort Adjustments.....</b>	<b>13</b>
<b>Batteries and Charging .....</b>	<b>16</b>
<b>Care and Maintenance .....</b>	<b>21</b>

# Introduction

## Safety

WELCOME to FeatherChair. The power chair you have purchased combines state-of-the-art components with **safety**, comfort, and styling in mind. We are confident that these design features will provide you with the conveniences you expect during your daily activities. Once you understand how to **safely** operate and care for your power chair, it should give you years of trouble-free operation and service.

**Read and follow** all instructions, warnings, and notes in this manual before attempting to operate your power chair for the first time. You must also read all instructions, warnings, and notes contained in any supplemental instructional booklets for the controller that accompanied your power chair before initial operation. Your **safety** depends upon you, as well as your provider, caretaker, or healthcare professional in using good judgment.

If there is any information in this manual which you do not understand, or if you require additional assistance for setup or operation, please contact your authorized provider. **Failure to follow the instructions in this manual and those located on your power chair can lead to personal injury and/or damage to the power chair, including voiding the warranty.**

## Purchaser's Agreement

By accepting delivery of this product, you promise that you will not change, alter, or modify this product or remove or render inoperable or unsafe any guards, shields, or other safety features of this product; fail, refuse, or neglect to install any retrofit kits from time to time provided by FeatherChair to enhance or preserve the safe use of this product.

## Shipping and Delivery

Before using your power chair, make sure your delivery is complete as some components may be individually packaged. If you do not receive a complete delivery, please contact your authorized provider immediately. Where damage has occurred during transport, either to the packaging or content, please contact the delivery company responsible.

***NOTE: If you ever lose or misplace your copy of this manual, contact us and we will be glad to send you a new one immediately.***

# Safety

## Product Safety Symbols

The symbols below are used on the power chair to identify warnings, mandatory actions, and prohibited actions. It is very important for you to read and understand them completely.

**NOTE: There are more warnings identified and explained in the Consumer Safety Guide that is included with your power chair. Please become familiar with all the warnings and safety information found in the Consumer Safety Guide.**



Read and follow the information in the owner's manual.



Locked and in drive mode.

Place the unit on level ground and stand to one side when changing from drive mode to freewheel mode or freewheel mode to drive mode.

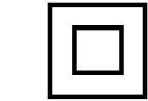

Class II Equipment

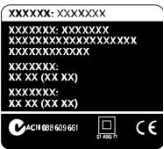

Power Chair information label



Manufactured in China



Do not remove the anti-tip wheels.

## General Guidelines



**MANDATORY! Do not operate your new power chair for the first time without completely reading and understanding this owner's manual.**

Your power chair is a state-of-the-art life-enhancement device designed to increase mobility. FeatherChair provides an extensive variety of products to best fit the individual needs of the power chair user. Please be aware that the final selection and purchasing decision regarding the type of power chair to be used is the responsibility of the power chair user, who is capable of making such a decision, and his/her healthcare professional (i.e., medical doctor, physical therapist, etc.).

The contents of this manual are based on the expectation that a mobility device expert has properly fitted the power chair to the user and has assisted the prescribing healthcare professional and/or the authorized provider in the instruction process for the use of the product.

There are certain situations, including some medical conditions, where the power chair user will need to practice operating the power chair in the presence of a trained attendant. A trained attendant can be defined as a family member or care professional specially trained in assisting a power chair user in various daily living activities.

As you begin using your power chair during daily activities, you will probably encounter situations in which you will need some practice. Simply take your time and you will soon be in full and confident control as you maneuver through doorways, on and off of lifts, up and down ramps, and over moderate terrain.

Below are some precautions, tips, and other safety considerations that will help you become accustomed to operating your power chair safely.

### **Pre-Ride Safety Check**

Get to know the feel of your power chair and its capabilities. FeatherChair recommends that you perform a safety check before each use to make sure your power chair operates smoothly and safely.

### **Perform the following inspections prior to using your power chair:**

- Check for proper tire inflation. Maintain but do not exceed the psi/bar/kPa air pressure rating indicated on each tire if equipped with pneumatic tires.
- Check all electrical connections. Make sure they are tight and not corroded.
- Check all controller connections to the power base. Make sure they are secured properly.
- Check the brakes. See "Care and Maintenance."
- Check battery charge. See "Batteries and Charging."
- Ensure the manual freewheel levers are in drive mode before sitting on the power chair.

***NOTE: If you discover a problem, contact your authorized provider for assistance.***

# Your Power Chair

## The Feather Power Chair

The Feather Power Chair is a power chair that you can easily fold for transportation or storage. The battery box slides into the rear of the power base. **See figures 1 and 2** for power chair components.

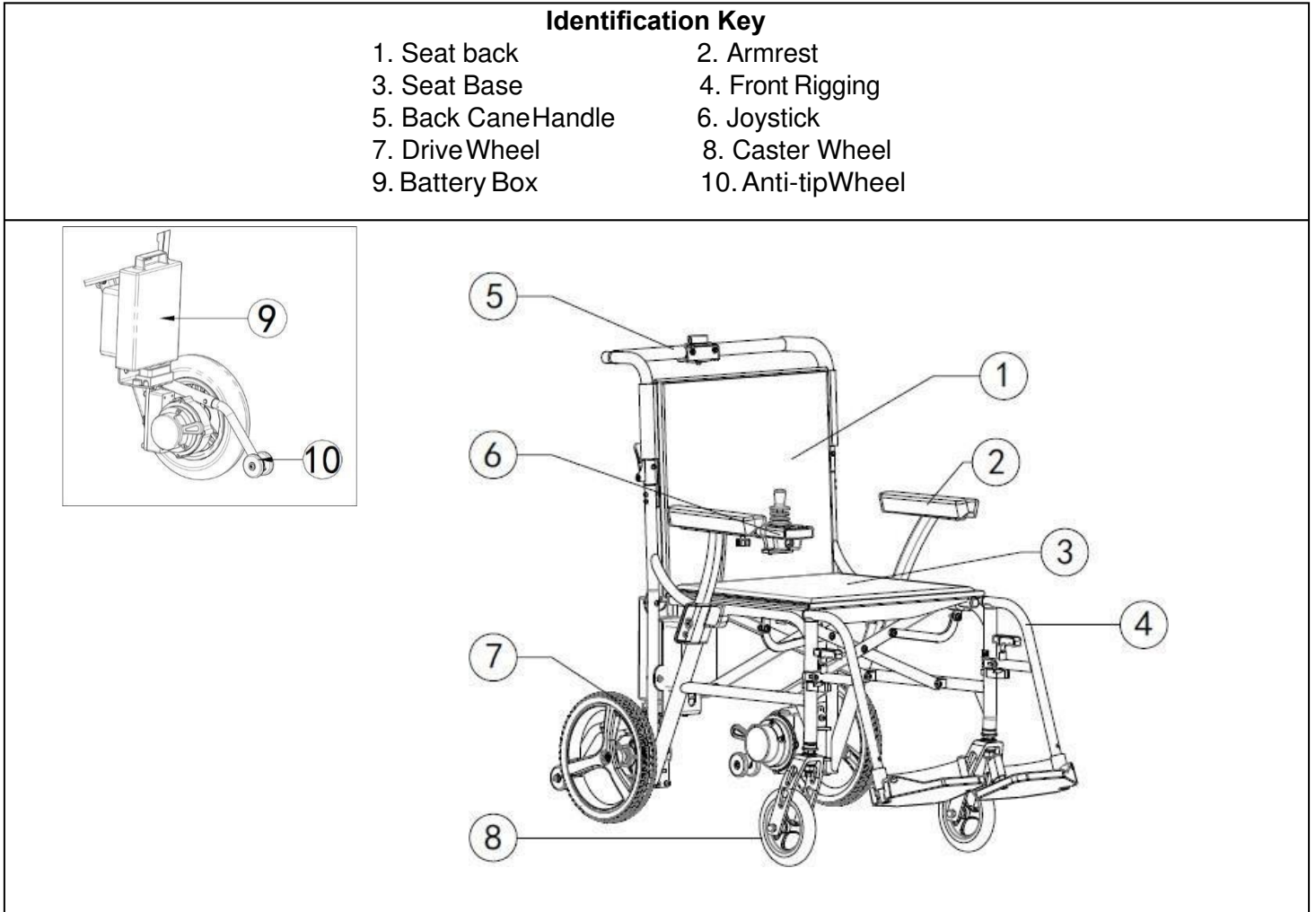

Figure 1. The Feather Power Chair

### Identification Key

- |                           |                         |
|---------------------------|-------------------------|
| 1. Manual Freewheel Lever | 2. Battery Box          |
| 3. Anti-tip Wheel         | 4. Storage Compartment  |
| 5. Battery Power Switch   | 6. Battery Charger Port |

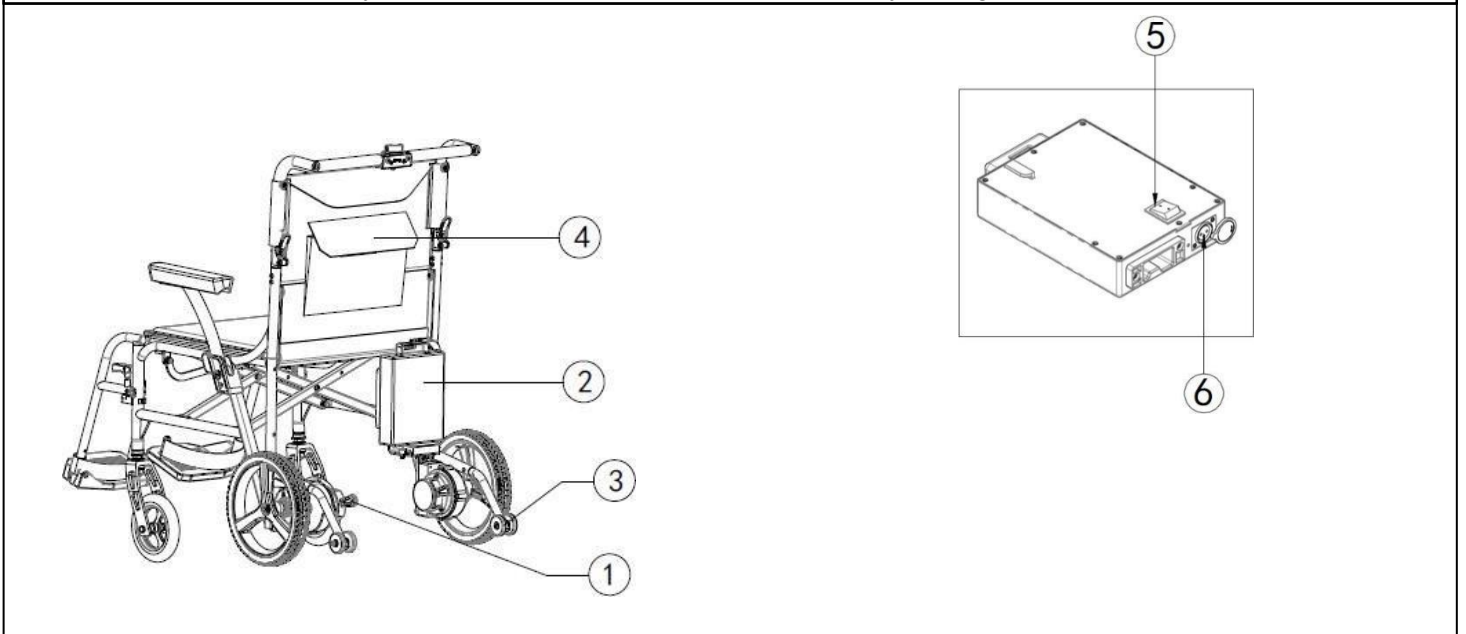

Figure 2. Power Base

### Electrical Components

The electrical components are located on the power base. The main circuit breaker is located on the back of the battery box, beneath the handle. **See figure 2.**

**Battery Box Charger Port:** This enables you to charge the battery when the battery box is removed from the power base. See “Batteries and Charging.”

**NOTE:** *The battery power switch also serves as the main circuit breaker. See below for more information.*

**Battery Power Switch:** This switch turns the battery power on and off. When the switch is in the “I” position, the battery is on. The battery can be powered off for long-term storage by switching it to the “0” position.

### Manual Freewheel Levers

For your convenience, your power chair has a manual freewheel lever on each motor. Manual freewheel levers enable you to disable the drive system in order to maneuver the chair manually.

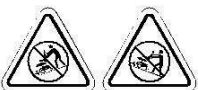

**WARNING!** Do not use the power chair while the drive motors are disengaged! Do

not disengage the drive motors when the power chair is on an incline or decline, as the unit could roll on its own! Only engage the freewheel mode when on a level surface.



**WARNING!** It is important to remember that when your power chair is in freewheel mode, the braking system is disengaged.

**WARNING!** Do not disengage the drive motors while the power chair is occupied.

**NOTE:** FeatherChair strongly recommends you do not charge your battery while in freewheel mode.

**NOTE:** You must turn off the power before disabling the drive systems; otherwise, you may get an error code on the controller. To clear this code, turn off the controller and place the power chair in drive mode. Then turn on the controller. The error message should be cleared. If not, contact an authorized provider.

**To engage or disengage the drive motors:**

1. Locate the lever on each motor. **See figure 3.**
2. Rotate the manual freewheel levers outward to disengage the drive motors (freewheel mode). **See figure 3.**
3. Rotate the manual freewheel levers inward to engage the drive motors (drive mode). **See figure 3.**



**WARNING!** Do not use the freewheel lever handles as tie-down points to secure this product.

## Anti-Tip Wheels

The anti-tip wheels are an integral and important safety feature of your power chair. They are attached to the frame at the rear of the chair. **See figures 2 and 3.**



**PROHIBITED!** Do not remove the anti-tip wheels or modify your power chair in any way that is not authorized by FeatherChair.

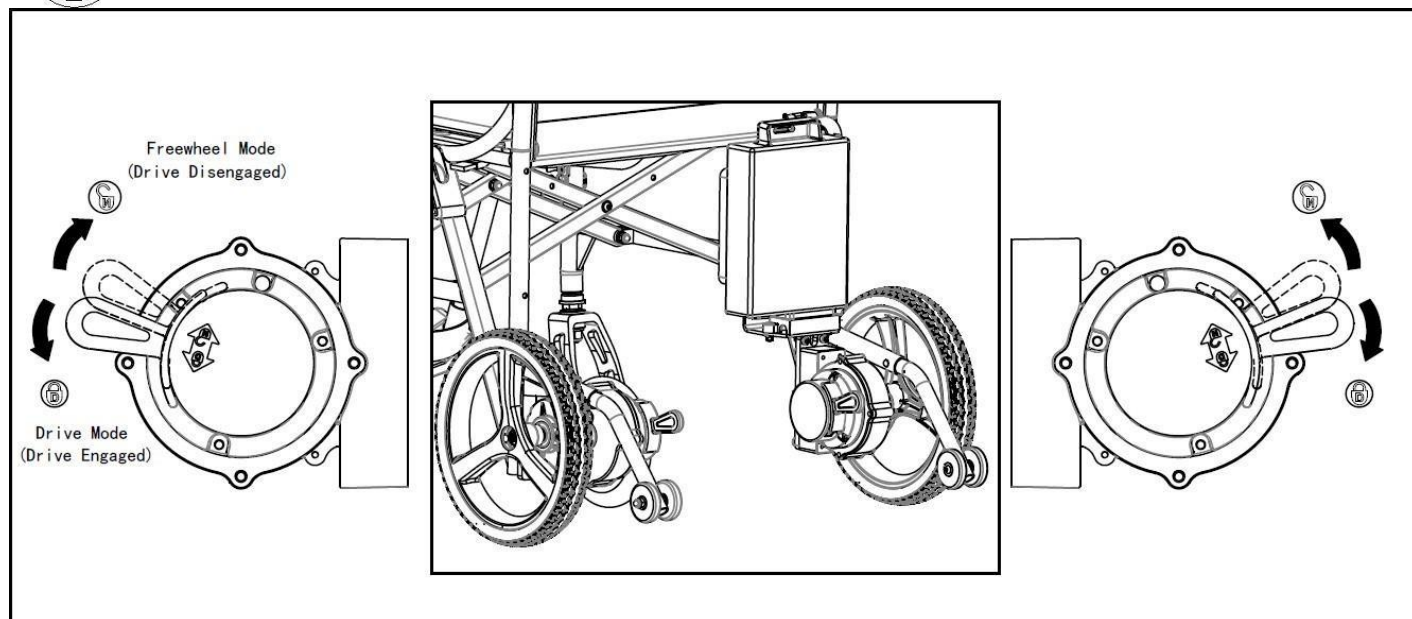

Figure 3. Freewheel Levers

## Assembly/Disassembly

### Initial Assembly

Your power chair may require some assembly either before initial use or after transportation. It may also require disassembly to make some comfort adjustments.

**NOTE: The battery case fastener must be fastened into the battery case fixing plate slot.**

### To assemble your power chair:

1. Unfold the power chair assembly. See “Folding and Unfolding.”
2. Install the battery box into the battery tray by sliding it vertically into the rear of the frame beneath the seat until the securement pin clicks into place. **See figure 4.**

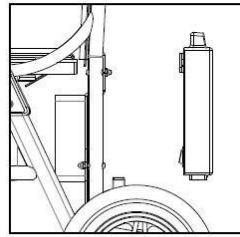
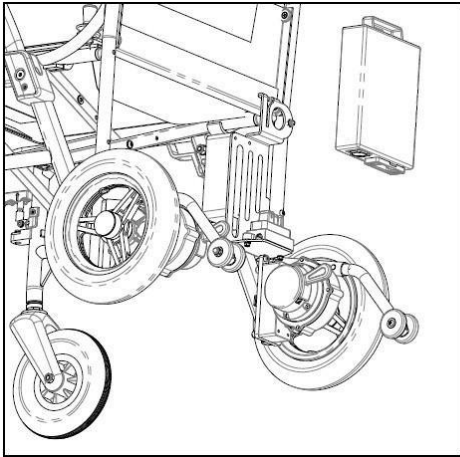

**Figure 4.**  
**Battery Box**  
**Removal/Installation**

3. Flip up the armrests.
4. Insert the controller Joystick into the armrest and tighten the thumbscrew, then latch the quick release handle. **See figure 6.** Hook the controller harness to the securement clips. **See figure 10.**

**NOTE: Ensure that the controller harness does not become pinched when folding and unfolding your power chair, as shown in figure 5. If pinching occurs, the harness was twisted prior to installation. Uninstall and untwist the controller harness, and ensure upon reinstallation that your power chair can fold and unfold without creating harness pinch points.**

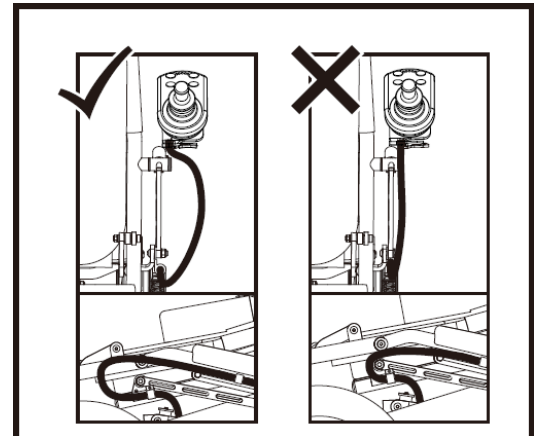

**Figure 5. Controller Harness Pinch Point**

5. Attach the cushion and seatback cover to the chair by
6. securing the reusable hook and loop fasteners together.  
Remove the battery charger from the box and plug into the controller charger port. Follow the charging instructions printed on the charger. **See figure 13.**



**MANDATORY!** Prevent controller harness damage! Avoid routing the controller harness on the outside of the armrest pad. Route the harness under the armrest or toward the inside of the armrest pad. Use correct tie-down points for the controller harness to prevent the harness from getting caught in the drive tires, pinched in the seat frame, or damaged when passing through doorways.

### Disassembly

The power chair disassembles into three components: the base, the battery box, and the controller.

#### To disassemble the power chair:

1. Turn off the power on the controller Joystick.
2. Place the power chair in drive mode, if not in drive mode already. See "Your Power Chair."
3. Unlatch the quick release handle and loosen the thumbscrew, and then remove the controller Joystick from the armrest.  
**See figure 6.**
4. Unlatch the quick release handle and loosen the thumbscrew, and then remove the cup holder from the other armrest.
5. Grasp the battery box handle and lift up the locking pin to disengage the box from the power base, then slide the battery box out of the power base. **See figure 4.**

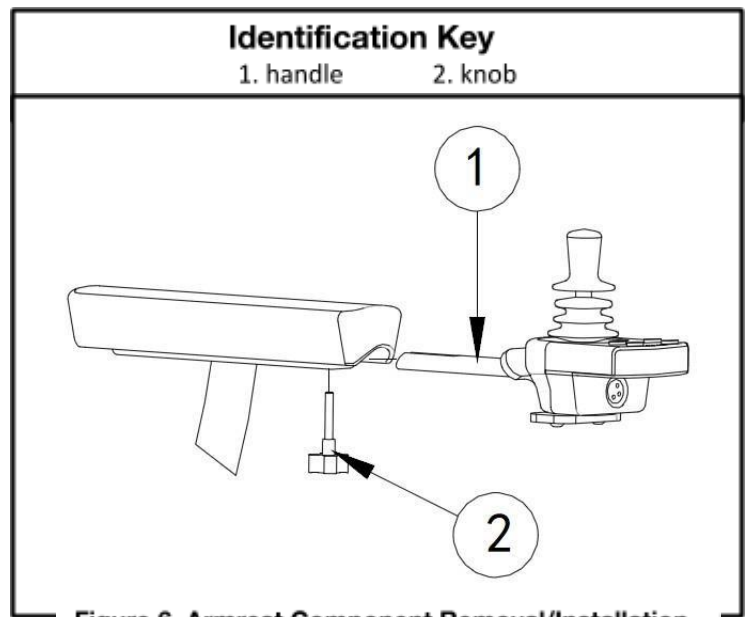

### Folding and Unfolding

Your power chair can be folded for easy transportation and storage.

#### To fold the power chair:

1. Fold the foot platform upwards toward the seat of the power chair.
2. Then hold both ends of the seat, lift up the seat from the middle. **See figure 7**
3. Press down both sides of the armrest.

#### To unfold the power chair:

1. Relieve the brake, stand at the front or back of the wheelchair.
2. Hold the both side of armrest and pull hard, one hand on the armrest and the other one to press down the seat. **See figure 8**



**WARNING!** To avoid injury, ensure the seat back is fully unfolded and the locking mechanism is engaged before sitting in your power chair.



**WARNING! Mind your hands.**

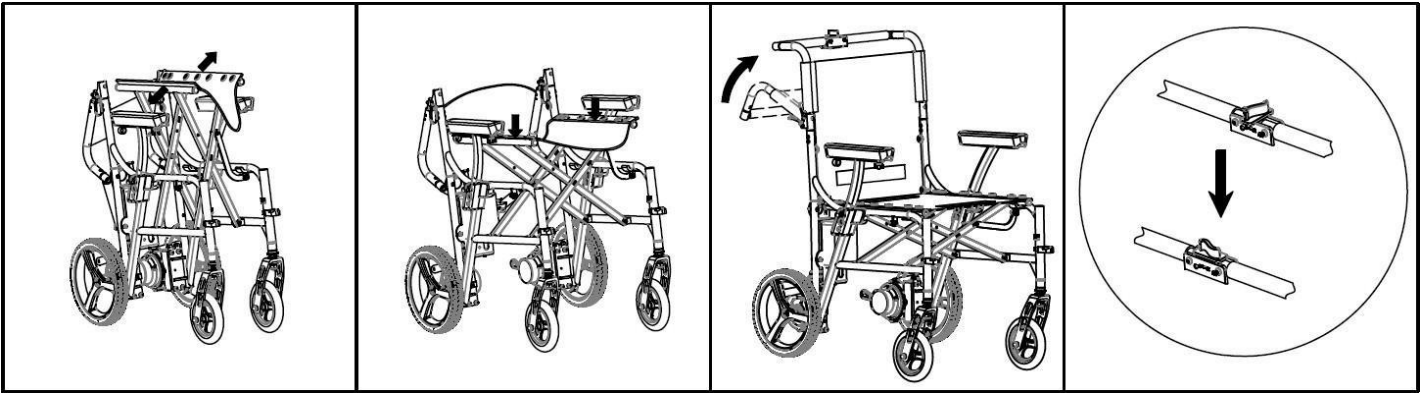

**Figure 7.**

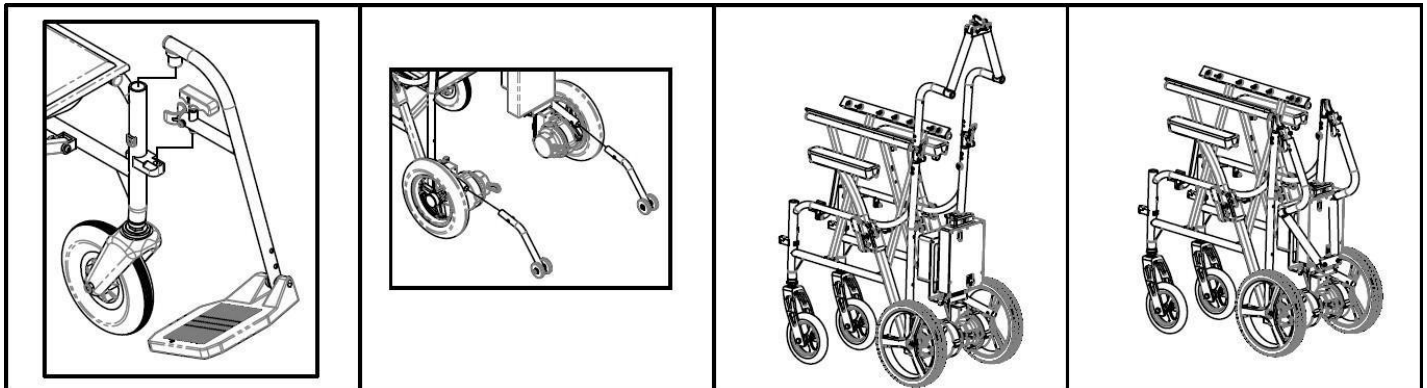

**Figure 8.**

**Opening of the backrest:**

Hold the handle and lift up. See figure 7



**Hold the handle and move upwards and forwards, confirm the backrest is folded properly.  
Mind your hands.**

**Folding of the backrest**

Hold the hand with one hand and press the back folding button with the other one. See figure 8.

**Assembling and removal of legrest:**

Lift the handle upwards as indicated by the yellow arrow and rotate it outwards, legrest shall be removed. And the converse is to assemble the legrest. See figure 8.

# Comfort Adjustments

## Comfort Adjustments

After becoming familiar with your power chair's operation, you may find the need to make some adjustments to increase your comfort. Use the steps below to make comfort adjustments.

**WARNING!** The center of gravity of your power chair was factory set to a position that meets the needs of the demographic majority of users. Your authorized provider has evaluated your power chair and made any necessary adjustments to suit your specific requirements. Do not change your seating configuration without first contacting FeatherChair Mobility Products or your authorized provider.



**WARNING!** Some power chair components are heavy. You may need assistance to lift or carry them. Please refer to the specification table for specific component weights before you disassemble the power chair.

**WARNING!** Remove the occupant from the power chair before making any adjustments.

### Armrest Backward

Pull the pin to flip the armrest backward.

1. Pin

Figure 9.

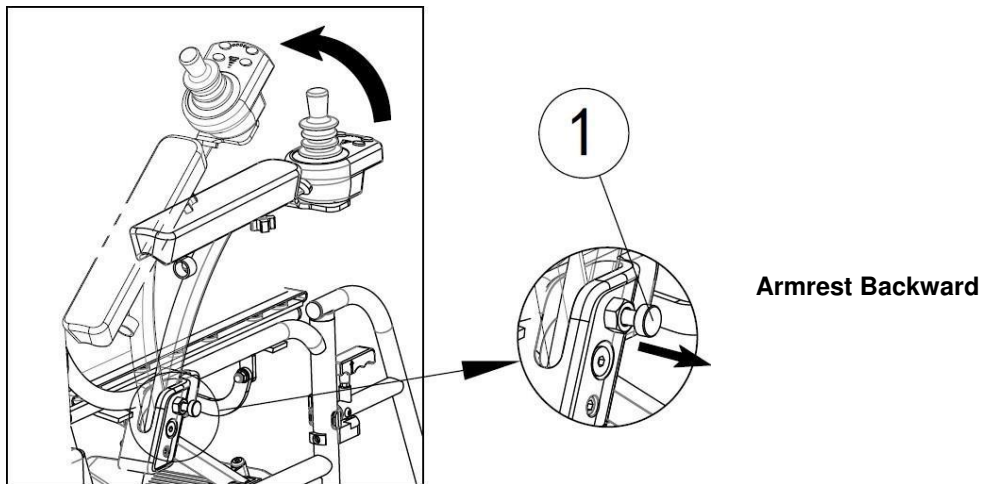

## Controller Position

You can position the controller for either left-hand or right-hand use. You can also adjust the controller position angle.



**WARNING!** Do not place the controller harness so that it can be pinched in the seat frame or the power base frame.

### To change the controller position:

1. Turn off the power to the controller.
2. Cut the wire ties securing the controller harness to the frame.
3. Unhook the controller harness from the securement clips. Uninstall the securement clips and reinstall them on the other side. **See figure 9.**
4. Flip up the controller armrest. Unlatch the quick release handle and loosen the thumbscrew. **See figure 9.**
5. Slide the controller out of the armrest.
6. Reroute the controller harness under the seat base to the other side.
7. Unlatch the quick release handle and loosen the thumbscrew in the other armrest.
8. Place the controller in the other armrest.
9. Tighten the thumbscrew to secure the controller and latch the quick release handle.
10. Flip up the armrest.
11. Use wire ties to secure the controller harness to the frame, and hook the controller harness to the securement clips. **See figure 10.** Ensure that the armrest can freely be raised and lowered without any tension on the harness so the securement clips do not become disconnected.

**NOTE:** The controller bracket offset will slightly alter the controller's positioning when rerouted to the left armrest.

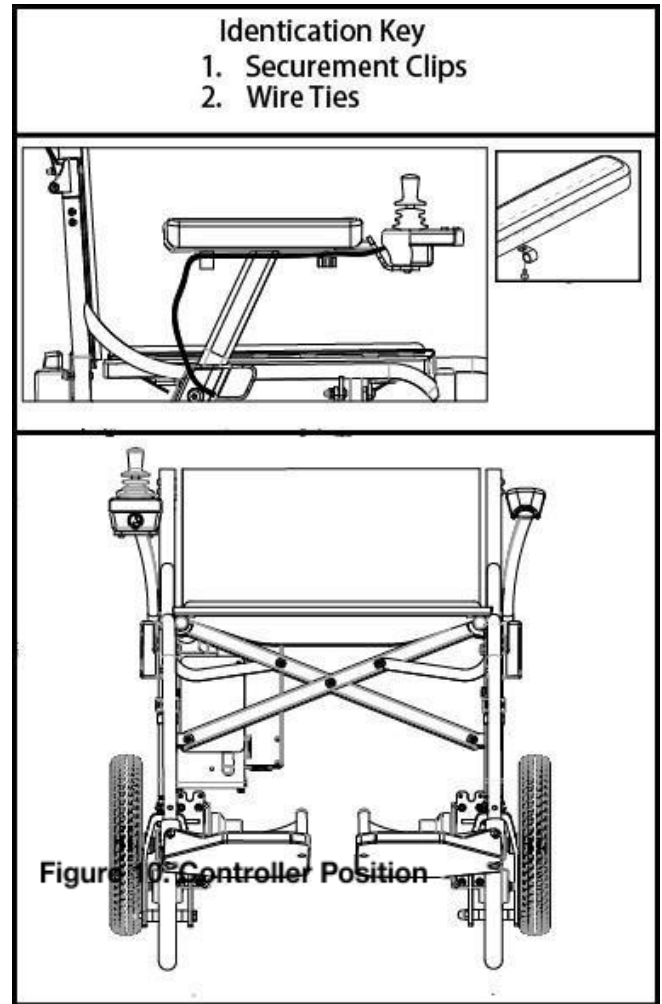

## Positioning Belt

Your power chair may be equipped with a positioning belt that can be adjusted for operator comfort. **See figure 11.** The positioning belt is designed to support the operator so that he/she does not slide down or forward in the seat. The positioning belt is not designed for use as a restraining device.



**WARNING! The positioning belt is not designed for use as a seat belt in a motor vehicle. Nor is your power chair suitable for use as a seat in any vehicle. Anyone traveling in a vehicle should be properly belted into seats approved by the vehicle manufacturer.**

**WARNING! The positioning belt should be secured at all times. Never allow the positioning belt to hang or drag on the floor as it may become entangled.**

### To adjust the positioning belt:

1. Once seated, insert the metal tab on one side of the belt into the plastic housing on the opposite side until you hear a click. **See figure 11.**
2. Pull the excess strap attached to the metal tab until it is secure, but not so tight as to cause discomfort.

### To release the positioning belt:

1. Press the push button mechanism on the plastic housing.

**MANDATORY! Make sure the positioning belt is properly secured to the power chair and is adjusted for operator comfort before each use.**



**MANDATORY! Inspect the positioning belt for loose parts or damage, including tears, worn spots, bent hardware, damaged latch mechanisms, dirt or debris, before each use of the power chair. If you discover a problem, contact your authorized provider.**

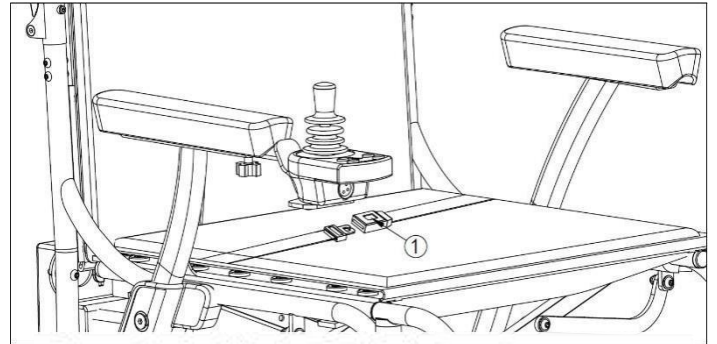

Figure 11. Positioning Belt Adjustment

## Batteries and Charging

### Batteries and Charging

Your power chair uses one long-lasting Lithium-Ion battery. This battery is sealed and maintenance-free. Since it is sealed, there is no need to check the electrolyte (fluid) level. Lithium-Ion batteries are designed to handle a longer and deeper discharge. Though they are similar in appearance to automotive batteries, they are not interchangeable. Automotive batteries are not designed to handle a long, deep discharge, and also are unsafe for use in power chairs.



**MANDATORY!** Battery posts, terminals, and related accessories may contain lead and lead compounds. Wear goggles and gloves when handling batteries and wash hands after handling.



**WARNING!** Contact your authorized provider if you have any questions regarding the battery in your power chair.

### Charging the Battery

The battery charger is essential in providing long life for your power chair battery. It is designed to optimize your power chair's performance by charging the battery safely, quickly, and easily. The battery charger is only functional when the charger power cord is plugged into an electrical outlet.



**PROHIBITED!** Removal of grounding prong can create electrical hazard. If necessary, properly install an approved 3-pronged adapter to an electrical outlet having 2-pronged plug access.



**PROHIBITED!** Never use an extension cord to plug in your battery charger. Plug the charger directly into a properly wired standard electrical outlet.



**PROHIBITED!** Do not allow unsupervised children to play near the power chair while the battery is charging. FeatherChair recommends that you do not charge the battery while the power chair is occupied.



**MANDATORY!** Read the battery charging instructions in this manual and in the manual supplied with the battery charger before charging the battery.



**WARNING!** Explosive gases may be generated while charging the battery. Keep the power chair and battery charger away from sources of ignition such as flames or sparks and provide adequate ventilation when charging the battery.

**WARNING!** You must recharge your power chair's battery with the supplied off-board charger. Do not use an automotive-type battery charger.

**WARNING!** Inspect the battery charger, wiring, and connectors for damage before each use. Contact your authorized provider if damage is found.



**WARNING!** Do not attempt to open the battery charger case. If the battery charger does not appear to be working correctly, contact your authorized provider.

**WARNING!** Be aware that the battery charger case may become hot during charging. Avoid skin contact and do not place on surfaces that may be affected by the heat.

**WARNING!** If the battery charger is equipped with cooling slots, then do not attempt to insert objects through these slots.



**WARNING!** If your battery charger has not been tested and approved for outdoor use, then do not expose it to adverse or extreme weather conditions. If the battery charger is exposed to adverse or extreme weather conditions, then it must be allowed to adjust to the difference in environmental conditions before use indoors. Refer to the manual supplied with the battery charger for more information.

**NOTE:** The Feather Power Chair battery can be charged with the battery box either installed on or removed from the power base.

**To charge the battery using the off-board charger:**

- |  |
|--|
| 1. Position the front of your power chair next to a standard electrical outlet.  |
| 2. Be certain the controller power is turned off and the freewheel levers are in the engaged position. See "Your Power Chair." |
| 3. Plug the off-board charger into the off-board charger/programming socket of the controller. <b>See figure 12.</b>           |
| 4. Plug the off-board charger into the electrical outlet.  |

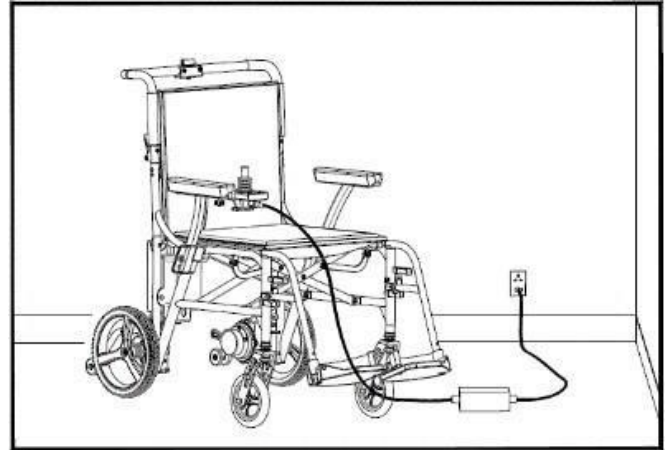

<b>WARNING!</b> The LED lights on the charger indicate different charger conditions at various times: charger power on and charging complete. If the LED does not indicate that charging is completed within 24 hours, unplug the charger from the outlet and contact your authorized FeatherChair Provider. Refer to the manual supplied with the charger for a complete explanation of these indicators.
--

5. When the battery is fully charged, unplug the off-board charger from the electrical outlet and then from the controller.

**NOTE:** The battery condition meter on your power chair controller displays an approximate reading of battery strength. Refer to Table 1 for battery condition meter codes.

5	55-100% battery remaining
4	35-55% battery remaining

3	20-34% battery remaining
2	12-19% battery remaining
1	<12% battery remaining
1st LED blinking	<5% battery remaining

**Table 1. Battery Condition Meter Codes**

**To charge the battery with the battery box removed from the power base:**

1. Remove the battery box from the power base. **See figure 4.**
2. Position the battery box next to a standard electrical outlet.
3. Plug the off-board charger into the battery box charger port. **See figure 13.**
4. Plug the off-board charger into the electrical outlet.

**NOTE: FeatherChair off-board chargers contain two lights. The red light indicates that power to the off-board charger is on. The green light indicates that the battery is fully charged. If your charger is not a FeatherChair off-board charger, follow the instructions supplied by the manufacturer.**

5. When the battery is fully charged, unplug the off-board charger from the wall outlet and then from the batterybox.
6. Reinstall the battery box to the power base.

**NOTE: Turn off the power to the controller before removing the battery box.**

**Frequently Asked Questions (FAQs)**

**How does the charger work?**

The battery charger takes the standard electrical outlet voltage (alternating current) and converts it to 24V DC (direct current). The battery uses a direct current to run your power chair. When the battery voltage is low, the charger works harder to charge the battery. As the battery voltage approaches full charge, the charger does not work as hard to complete the charging cycle. When the battery is fully

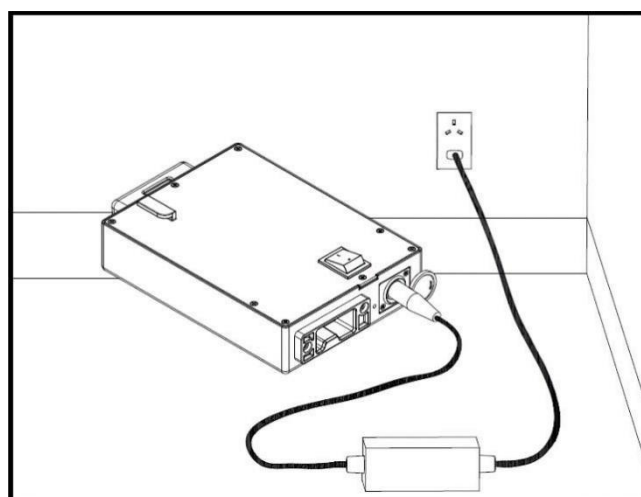

**Figure 13. Battery Charging with the Battery Box**

charged, the amperage from the charger is nearly at zero. This is how the charger maintains a charge but does not overcharge the battery.

### **Can I use a different battery charger?**

You should use the charger supplied with the power chair. It is the safest, most efficient tool to charge the battery. We do not recommend using other types of chargers (e.g., an automotive battery charger).

***NOTE: Your power chair's charger will not operate after the battery has been discharged to nearly zero capacity. If this happens, call an authorized provider for assistance.***

### **How often must I charge the battery?**

Many factors come into play when deciding how often to charge the battery. You may use your power chair all day on a daily basis or you may not use it for weeks at a time.

#### **Daily Use**

If you use your power chair on a daily basis, charge the battery as soon as you are finished using your power chair. Your power chair will be ready each morning to give you a full day's service. It is recommended that you charge the battery at least 8 to 14 hours after daily use. FeatherChair recommends that you charge your battery for an additional 4 hours after the battery charger indicates that charging is complete.

#### **Infrequent Use**

If you use your power chair infrequently (once a week or less), you should charge the battery at least once per week for 12 to 14 hours.

***NOTE: Keep your battery fully charged and avoid deeply discharging your battery. Refer to the manual supplied with the battery charger for charging instructions.***

### **How can I get maximum range or distance per charge?**

Rarely do you have an ideal driving situation such as smooth, flat, hard terrain with no wind, hills, or curves. More often you are presented with hills, pavement cracks, uneven and loosely packed surfaces, curves, and wind. All of these factors will affect the distance or running time per battery charge. Below are a few suggestions for obtaining the maximum range per charge:

- Always charge the battery fully prior to your trip.
- Plan your trip in advance to avoid inclines if possible.
- Limit baggage weight to essential items.
- Try to maintain an even speed and avoid stop-and-go driving.

### **What type of battery should I use?**

We recommend a FeatherChair-supplied Lithium-Ion battery that is sealed and maintenance-free. Refer to the specifications table for more information regarding the battery used with your power chair.



**WARNING! Corrosive chemicals contained in batteries. Use only Lithium-Ion batteries to reduce the risk of leakage or explosive conditions.**

### **Why does my new battery seem weak?**

Like nickel-cadmium batteries, Lithium-Ion batteries have a “memory” effect. Lithium-Ion batteries are specifically designed to provide power, drain down their charge, and then accept a relatively quick recharge. If the batteries are continually recharged after only being partially discharged, they lose their ability to hold a full charge.

We work closely with our battery manufacturer to provide a battery that best suits your power chair’s specific demands. Fresh batteries arrive regularly at FeatherChair and are promptly shipped with a full charge. During shipping, the battery encounters temperature extremes that may influence initial performance. Heat robs the charge from the battery, and cold slows the power available and extends the time needed to recharge the battery (just as with a car battery).

It might take a few days for the temperature of the battery to stabilize and adjust to its new ambient temperature. More importantly, it will take a few “charging cycles” (a full drain—then a full recharge) to establish the critical chemical balance that is essential to the battery’s peak performance and long life. It will be well worth it to take the time to break in your battery properly.

### **How can I ensure maximum battery life?**

A fully charged battery will provide reliable performance and extended battery life. Keep your power chair’s battery fully charged whenever possible. Batteries that are infrequently charged, repeatedly charged after only a partial discharge, or stored without a full charge may be permanently damaged, causing unreliable power chair operation and limited battery life.

***NOTE: The useful life of a battery is quite often a reflection of the care it receives.***

### **How should I store my power chair and its battery?**

If you do not use your power chair regularly, we recommend maintaining battery vitality by charging the battery at least once per week.

If you do not plan on using your power chair for an extended period, fully charge the battery prior to storage. Flip the battery switch to the off or “0” position, disconnect the battery, and store the power chair in a warm, dry environment. Avoid temperature extremes, such as freezing and excessively hot conditions, and never attempt to charge a frozen battery. A cold or frozen battery should be warmed for several days prior to recharging.

### **What about public transportation?**

The FeatherChair-supplied Lithium-Ion batteries are designed for application in power chairs and other mobility vehicles. Transport of the item on commercial aircraft is subject to federal regulations and airline policy. We suggest you contact the carrier’s ticket counter in advance to determine that carrier’s specific requirements, and to ensure your power chair and its Lithium-Ion battery are permitted.

### **What about shipping?**

If you wish to use a freight company to ship your power chair to your final destination, repack your power chair in the original shipping container if possible and ship the battery in a separate box.

## Care and Maintenance

### Care and Maintenance

Your Powerchair is a sophisticated power chair. Like any motorized vehicle, it requires routine maintenance checks. You can perform some of these checks, but others require assistance from an authorized provider. Preventive maintenance is very important. If you follow the maintenance checks in this section as scheduled, you can help ensure that your power chair gives you years of trouble-free operation. If you have any doubt as to your power chair's care or operation, contact an authorized provider.



**WARNING! Do not service the power chair when the seat is occupied.**

Your power chair, like most electrical equipment, is susceptible to damage from the elements. Avoid damp areas of anykind.



**WARNING! Direct or prolonged exposure to water or dampness could cause the power chair to malfunction electronically and mechanically. Water can cause electrical components to corrode and the chair's frame to corrode. Power chairs should be examined periodically for signs of corrosion caused by water exposure, bodily fluid exposure, or incontinence. Damaged components should be replaced or treated immediately.**

### Should your power chair come in contact with water:

1. Dry your power chair as thoroughly as possible with a towel.
2. Allow your power chair to sit in a warm, dry place for 12 hours to allow unseen water to evaporate.
3. Check the controller operation and the brakes before using your power chair again.
4. If any inconsistencies are found, take your power chair to an authorized provider. Power chairs that are frequently exposed to sources of water, such as incontinence, should be inspected often for corrosion and electronic components may need to be replaced frequently.

### Temperature

- Some of the parts of your power chair are susceptible to extreme changes in temperature. Always keep your power chair between the temperatures of 18°F (-8°C) and 122°F (50°C).
- In extremely cold temperatures the battery may freeze. The specific temperature at which it freezes depends on a number of factors, such as battery charge, usage, and composition of the battery (e.g., Lithium-Ion).

### General Guidelines

- Avoid knocking or bumping the controller.
- Avoid prolonged exposure of your power chair to extreme conditions, such as heat, cold, or moisture.
- Keep the controller clean.
- Check all connectors to ensure that they are all tight and secured properly.
- If your power chair is equipped, make sure pneumatic tires are inflated to the psi/bar/kPa air pressure rating indicated on each tire.



**WARNING! Make sure pneumatic tires are inflated to the psi/bar/kPa air pressure rating**

indicated on each tire. Do not underinflate or overinflate your tires. Low pressure may result in loss of control, and overinflated tires may burst. Overinflating tires can cause them to explode.

**WARNING! Do not use a high pressure hose to inflate your tires.**

- Use a rubber conditioner on the tire sidewalls to help preserve them.



**WARNING! Never use a rubber conditioner on the tread areas of the tires; doing so may make the tires slippery and cause your power chair to skid.**

- All wheel bearings are pre-lubricated and sealed. They require no subsequent lubrication.
- Check all electrical connections. Make sure they are tight and are not corroded. Refer to the battery wiring label for the correct wiring layout.



**WARNING! Even though the power chair has passed the necessary testing requirements for ingress of liquids, you should keep electrical connections away from sources of dampness, including direct exposure to water or bodily fluids and incontinence. Check electrical components frequently for signs of corrosion and replace as necessary.**

### Daily Checks

- With the controller turned off, check the joystick. Make sure it is not bent or damaged and that it returns to the neutral position when you release it. Check the rubber boot around the base of the controller for damage. Visually inspect the boot. Do not handle or try to repair it. See an authorized provider if there is a problem.
- Visually inspect the controller harness. Make sure that it is not frayed, cut, or has any wires exposed. See an authorized provider if there is a problem.
- Check for flat spots on solid tires. Flat spots could adversely affect stability.
- Inspect the seating system, armrests, and front riggings for loose hardware, stress points or damage. See your authorized provider if there is a problem.

### Weekly Checks

- Inspect the controller for signs of corrosion. Contact an authorized provider if necessary.
- Ensure that all parts of the controller system are securely fastened to your power chair. Do not overtighten any screws.
- Check for proper tire inflation. If a tire does not hold air, contact your authorized provider for replacement of the tube.
- Check the brakes. This test should be carried out on a level surface with at least 3 feet (1 meter) of clearance around your powerchair.

### To check the brakes:

1. Turn on the controller and turn down the speed level on your power chair.
2. After one second, check the battery condition meter. Make sure that it remains on.
3. Slowly push the controller forward until you hear the electric brakes click. Immediately release the controller. You must be able to hear each electrical brake operating within a few seconds of controller movement. Repeat this test three times, pushing the controller rearwards, then left, and then right.

### Monthly Checks

- Check that the anti-tip wheels do not rub the ground when you operate the power chair. Adjust them as necessary.

- Check for drive tire wear. See an authorized provider for repair
- Check the caster wheels for wear. Replace them as necessary.
- Check the caster forks for damage or fluttering which indicates that they may need to be adjusted or have the bearings replaced. See an authorized provider for repair.
- Check the entire power chair for loose hardware and changes in the function or performance of the power chair. See your authorized provider for service and repair.
- Keep your power chair clean and free of foreign material, such as mud, dirt, hair, food, drink, etc.

### Yearly Checks

Take your power chair to an authorized provider for yearly maintenance, especially if you use your chair on a daily basis. This helps ensure that your power chair is functioning properly and helps prevent future complications.

### Storage

Your power chair should be stored in a dry place, free from temperature extremes. When storing, disconnect the battery from the power chair and flip the battery switch to the “0” position. See “Batteries and Charging.”



**WARNING! If you fail to store the unit properly, the frame can corrode and the electronics can be damaged.**

Batteries that are regularly and deeply discharged, infrequently charged, stored in extreme temperatures, or stored without a full charge may be permanently damaged, causing unreliable performance and limited service life. It is recommended that you charge the battery periodically throughout periods of prolonged storage to ensure proper performance.

You may wish to place several boards under the frame of your power chair to raise it off of the ground during periods of prolonged storage. This takes the weight off the tires and reduces the possibility of flat spots developing on the areas of the tires contacting the ground.

### Disposal of Your Power Chair

Your power chair must be disposed of according to applicable local and national statutory regulations. Contact your local waste disposal agency or authorized provider for information on proper disposal of power chair packaging, metal frame components, plastic components, electronics, batteries, neoprene, silicone, and polyurethane materials.

### Frame Cleaning and Disinfection

- Use a damp cloth and mild, non-abrasive cleanser to clean the plastic and metal parts of your power chair. Avoid using products that may scratch the surface of your chair.
- If necessary, clean your product with an approved disinfectant. Make sure the disinfectant is safe for use on your product before application.



**WARNING! Follow all safety instructions for the proper use of the disinfectant and/or cleaning agent before applying it to your product. Failure to comply may result in skin irritation or premature deterioration of upholstery and/or power chair finishes.**

## Cushion Cleaning and Disinfection

The cushions can be easily cleaned.



**WARNING! Do not use bleach when washing the cushions. Doing so may cause damage to the cushions**

**WARNING! Follow all safety instructions for the proper use of the disinfectant and/or cleaning agent before applying it to your product. Failure to comply may result in skin irritation or premature deterioration of upholstery and/or power chair finishes.**

### To clean the cushions:

1. Remove the cushions by detaching the reusable hook and loop fasteners that secure the cushions, and then pulling the cushions toward you.
2. Using a damp cloth and a mild, non-abrasive cleanser, spot clean the cushions as necessary.
3. Allow the cushions to air dry.



**WARNING! Never submerge the cushions in water. Doing so may cause damage to the cushions. WARNING! Do not attempt to put cushions in a dryer. This may cause shrinking.**

4. Once the cushions are dry, position the cushions so that the reusable hook and loop fastener tabs face the seat and seatback. Place the cushion over any lumbar support(s) and then secure the cushions to the seat and seatback using the reusable hook and loop fasteners.

## Wheel Replacement

If your chair is equipped with a solid tire insert, then you must replace the whole wheel assembly. If you have pneumatic tires, you can replace the tire or the tube. Replacement wheel assemblies are readily available through an authorized provider.

**WARNING! The wheels on your power chair should only be serviced by an authorized provider or a qualified technician.**



**WARNING! Be sure that the power to the controller is turned off and the power chair is not in freewheel mode before performing this procedure.**

**WARNING! When changing the tire, remove only the center lug nut and washer, then remove the wheel. If any further disassembly is required, deflate the tire completely or it may explode.**

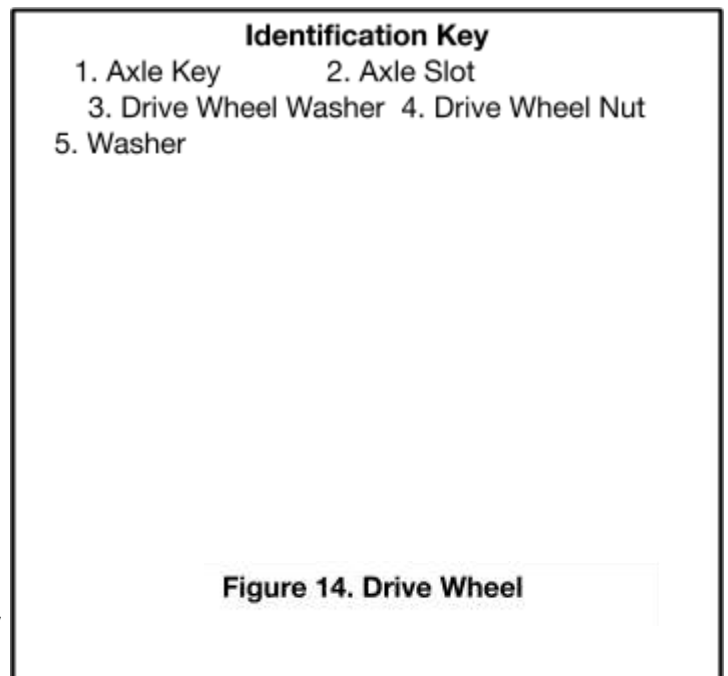

See figure 14.

### To change the wheel:

1. Turn off the power to the controller.
2. Set the power chair up on blocks.
3. Remove the drive wheel nut and washer from the axle.
4. If you are changing a pneumatic tire, completely deflate it before removing the wheel.

5. Remove the old tube from the pneumatic tire and replace it with a new tube or replace the entire assembly if it is a solid tire.
6. Slide the new wheel back onto the shaft. Make sure that the key is in the axle slot



**WARNING!** Ensure that the axle key is properly installed into the axle slot when mounting the wheel. If not installed securely, the braking and drive systems are disengaged which may cause personal injury or product damage.

7. Inflate the pneumatic tire to the psi/bar/kPa air pressure rating indicated on each tire.
8. Reinstall the drive wheel nut and washer onto the axle and tighten.



**WARNING!** Make sure both the nut and washer are reinstalled and tightened properly.

9. Remove the power chair from the blocks.

## Battery Replacement

A battery wiring diagram is printed on a decal located inside the battery box. See the product specifications for correct battery specifications.



**MANDATORY!** Battery terminals and related accessories may contain lead and lead compounds. Wear goggles and gloves when handling batteries and wash hands after handling.

**WARNING!** The battery in your power chair should only be serviced or replaced by an authorized provider or a qualified technician.



**WARNING!** Do not replace the battery when the seat is occupied.



**WARNING!** Power chair batteries may be heavy. See product specifications. If you are unable to lift that much weight, be sure to get help. Use proper lifting techniques and avoid lifting beyond your capacity.

**PROHIBITED!** Keep tools and other metal objects away from the battery terminals. Contact with tools can cause electrical shock.

**NOTE: For a replacement power chair battery, please contact your authorized provider.**

**NOTE: For a replacement power chair battery, please contact your authorized provider.**

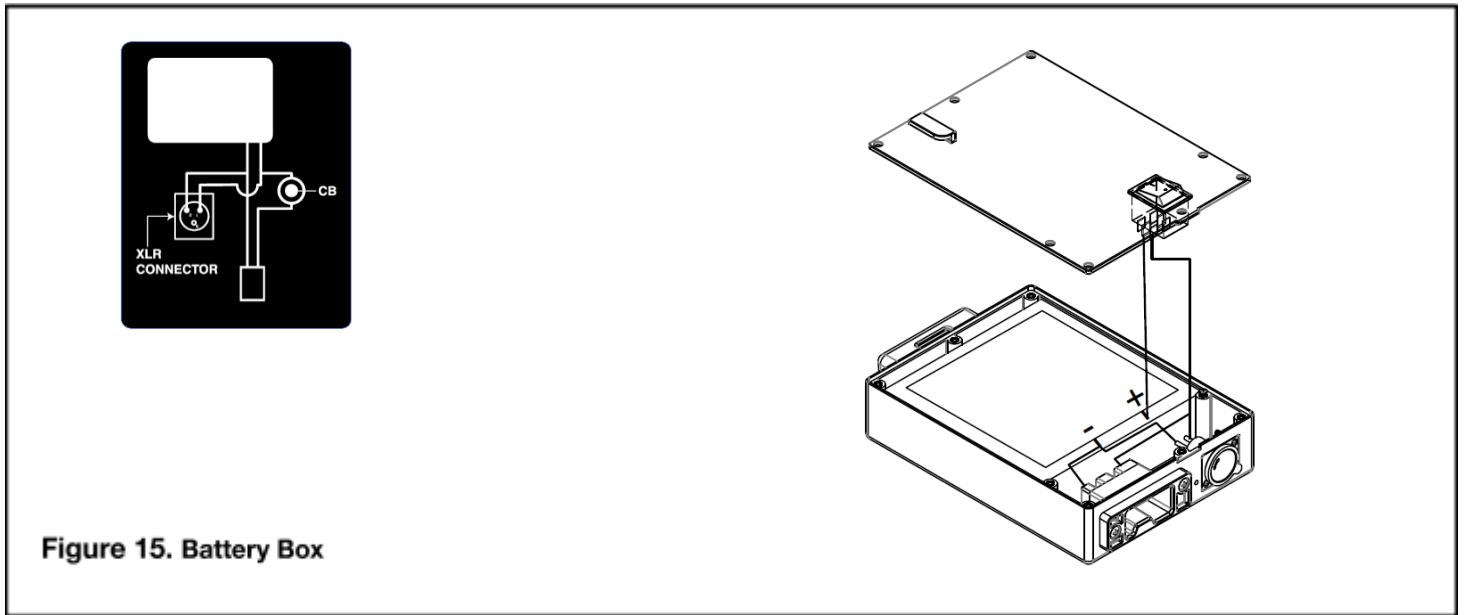

### When to See An Authorized provider for Service

The following symptoms could indicate a serious problem with your power chair. If necessary, contact an authorized provider. When calling, have the model number, serial number, nature of the problem, and the error code if available.

- Motor noise
- Frayed harnesses
- Cracked or broken connectors
- Uneven wear on any of the tires
- Jerky motion
- Pulling to one side
- Bent or broken wheel assemblies
- Does not power up
- Powers up, but does not move
- Loose seat or seating components

### Corrective Maintenance

If the battery condition meter does not light up when you turn on the power:

- Check the harness connections. Make sure they are tight.
- Check the circuit breaker. Reset it if necessary.
- Check the battery connections.

If the above conditions prove normal, you can load test the battery with a battery load tester. These testers are available at automotive parts stores. Disconnect the battery before load testing and follow the directions that come with the load tester. If the battery fails the load test, replace it. If your power chair still does not power up, contact an authorized provider.

## Specifications

Model	Feather Power Chair
Class of Use	Class A
Overall length with legrest	41.73"
Overall width	23.62"
Overall height	35"
Folded length	28.35"
Folded width	13.39"
Folded height	28"
Total mass	33 lbs.
Energy consumption	13 miles
Dynamic stability uphill	6°
Obstacle climbing	2"
Maximum speed forward	3.7 mph
Minimum braking distance from max speed	39.37"
Seat plane angle	5.5°
Effective seat depth	16.5"
Effective seat width	17.72"
Seat surface height at front edge	16.9"
Backrest angle	9°
Backrest height	16"
Footrest to seat distance	18.11"
Leg to seat surface angle	72°
Armrest to seat distance	6.7"
Horizontal location of axle	3"
Minimum turning radius	47.24"
Maximum occupant mass	<b>242.5 lbs.</b>
Battery charger rating	Input:100-240VAC,50/60Hz,1.2A Output:24VDC,2.0A
Battery specifications	Rated voltage: 24V Rated capacity: 10.4Ah Battery set mass: 2 lbs. per battery Size: 7.9" x 3.9" x 5.9" I5: 2.0 C5: 10.4Ah
Controller specifications	Nominal battery voltage: 24V; Operating voltage range: 18-30Vdc; Nominal drive current limit: up to 25A per channel; Rated brake current: 1Amax.

Rating	Input: 24 VDC Max. loading weight: 242.5lbs. Max. speed: 3.7 mph
Motor specifications	Rated voltage: 24 Vdc; Rated input power: 120W; Max. motor speed: 3.7mph
Front wheel	6"
Rear wheel specifications	Outer diameter/Tire width: 9.8" x 2.13" Material: PU Solid tire
Warranty on Frame	One Year Limited
Warranty on Wearable Parts	Six Months Limited
Warranty on Batteries	Three Months Limited